

calomax | **Contour**

Counter-top Catering Water Boiler

**INSTALLATION, OPERATION AND MAINTENANCE
MANUAL**

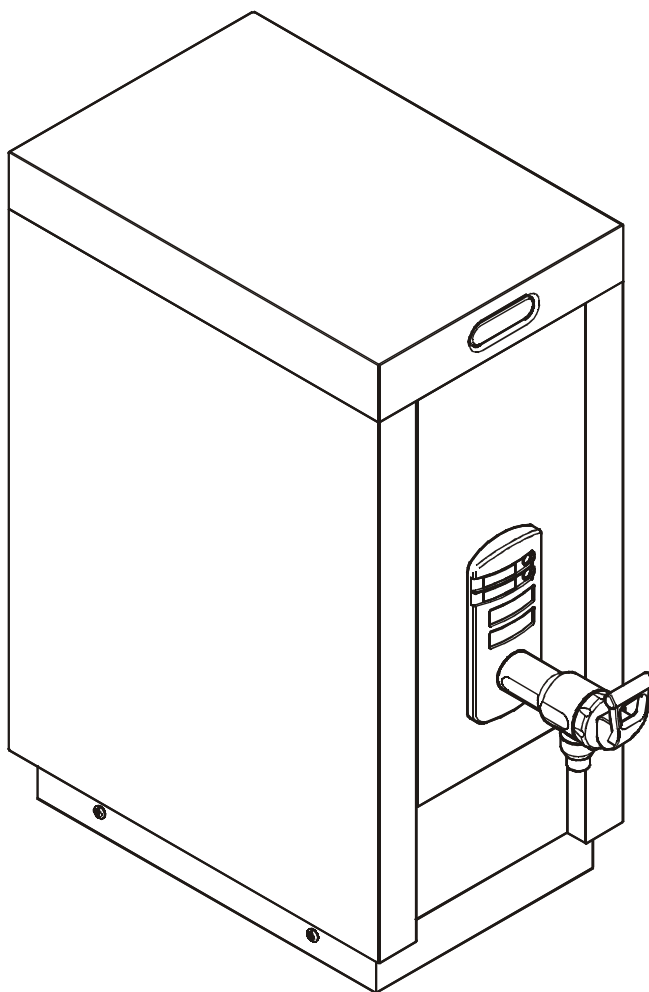

**Read these instructions thoroughly before
commencing installation or undertaking
maintenance work.**

Issue 4 -DCR586 : 16/1/03

TEL: 0113 249 6681

FAX: 0113 235 0358

www.calomax.co.uk

CONTENTS

1. PARTS IDENTIFICATION.	PAGE 1
2. PLANNING THE INSTALLATION.	2
2.1 Water Requirements	2
2.2 Electrical Requirements	2
2.3 Installation Location	2
2.4 Vent/Overflow Pipe Requirements.	2
3. INSTALLATION.	3
4. COMMISSIONING	3
5. USER INSTRUCTIONS.	3
5.1 Cleaning	4
5.2 Service indicator light	4
6. MAINTENANCE	4
6.1 Scale	4
6.1.1 Checking the Extent of Scale Formation	4
6.1.2 De-scaling	4
6.2 Replacing the Element and Thermistors	5
6.3 Replacing the Printed Circuit Board (P.C.B)	5
6.4 Replacing the Solenoid.	5
6.5 Checking the Overflow Screen	5
6.6 Adjusting the Water Temperature Set Point	5
7. CIRCUIT DIAGRAM.	6

IF PARTS REQUIRED ARE NOT IDENTIFIED PLEASE CONTACT CALOMAX LTD

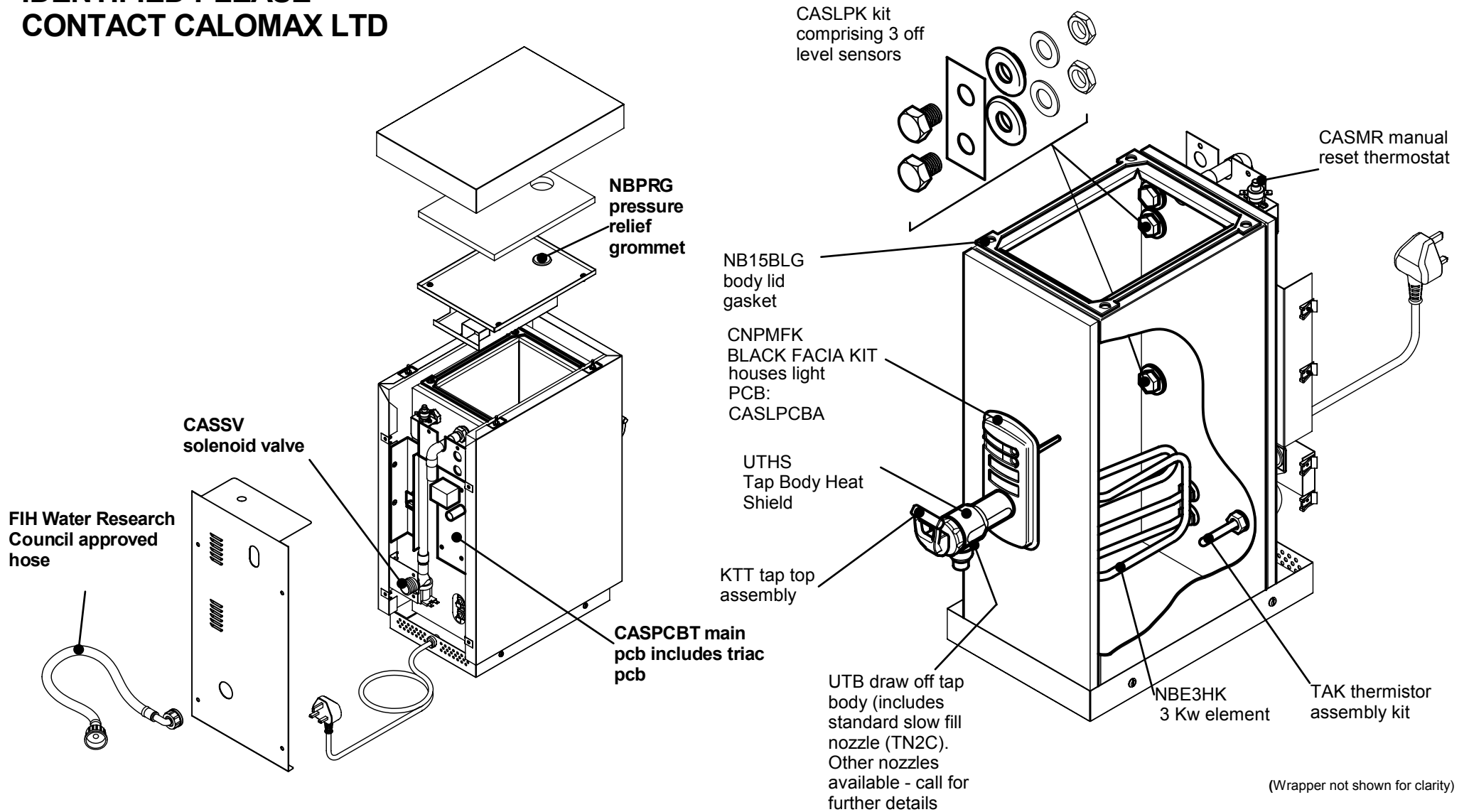

2. PLANNING THE INSTALLATION

All installation and maintenance work must be carried out by competent persons

2.1 Water Requirements

The unit is designed to be connected to a cold water rising mains supply, using 15mm Table 'X' copper tube, with a minimum pressure of 20 KPa (0.2 bar) and a maximum pressure of 1000 KPa (50 bar).

So as to comply with the U.K. Water Supply Regulations a single-check valve must be fitted to the cold water mains supplying the boiler. It is also recommended that an isolating valve be fitted to the mains water supply to the boiler to facilitate maintenance.

The formation of scale in hard water areas is a problem associated with all hot water appliances. Damage to the boiler caused by excessive scale deposits is not covered by the manufacturer's warranty.

2.2 Electrical Requirements

The installation must comply with the current I.E.E. Wiring regulations, if in doubt consult a qualified electrician.

This appliance must be earthed.

The boiler complies with the Electrical Equipment Safety Regulations (SI1994/3260) and has been independently tested to BS EN 60335-2-63.

The boiler operates a nominal 3 kW element at 240V, 50Hz. supply. A circuit diagram is provided on page 6.

Fig 1.

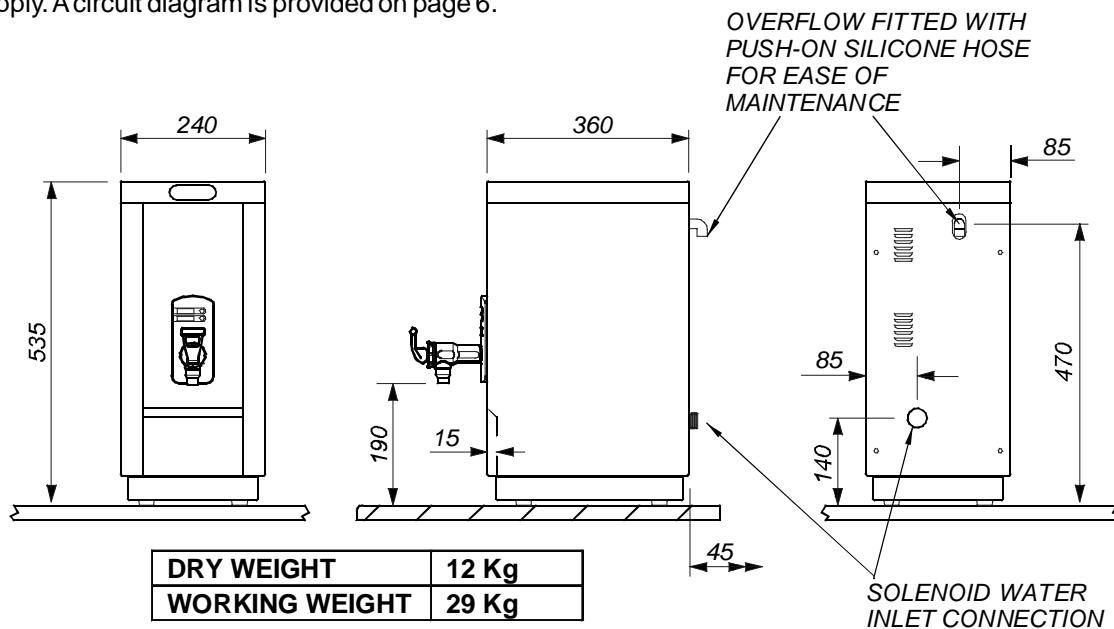
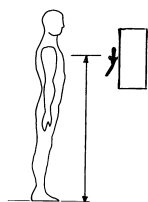

Fig 2.



The height from floor to draw off tap handle should be 1200mm +/- 100mm

2.3 Installation Location

Ensure the counter top is of suitable construction to support the working weight of the boiler

See fig.1.

To comply with recommendations from the health and safety executive it is important that due consideration be given to the safe operation of the controls of the boiler. The boiler should therefore be mounted in such a manner that the operator can stand directly facing the machine with the controls at the recommended height. See fig. 2

Consideration should also be given to the servicing requirements of the machine.

2.4 Vent / Overflow Pipe Requirements

The vent and overflow pipe should be extended on site using 15mm Speed-fit plastic tube or 15mm Table 'X' copper tube. The pipe must be laid with a **continuous fall**, discharging to a safe and visible position. **The vent and overflow pipe should not be connected directly to a soil pipe and should never be allowed to become blocked or restricted. See fig 3**

Fig. 3

VENT AND OVERFLOW PIPEWORK

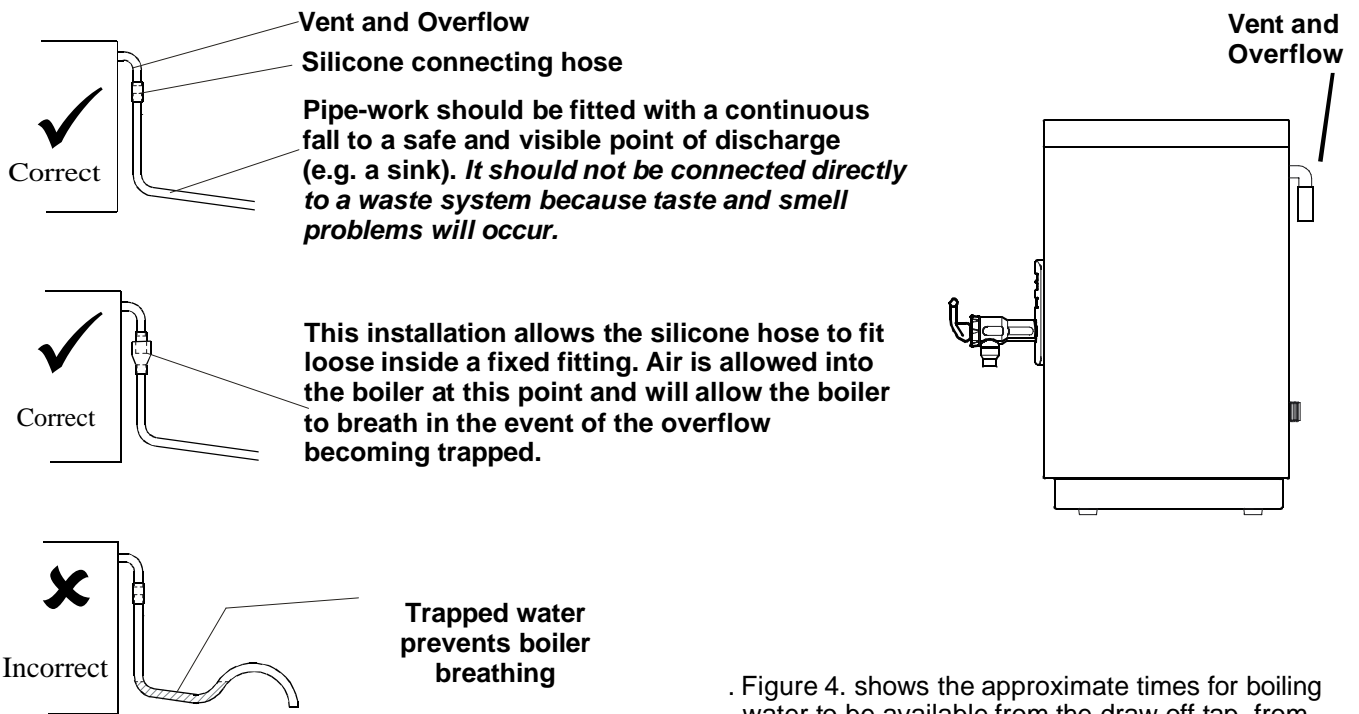

3. INSTALLATION

1. The boiler is supplied with a Water Research Council approved flexible water connection hose. This hose should be connected to the mains water supply using an isolating valve and then fitted to the machine solenoid valve inlet.

2. The vent / overflow pipe should be extended on site using 15mm Table 'x' copper tube as described in fig3. ***The overflow pipe must be fitted and arranged such that the outlet position is safe, visible and external to the boiler. The overflow pipe must not be connected directly to a soil pipe and should never be allowed to become blocked or restricted.***

3. All Contour machines are pre-wired with a 13A plug and lead for use with a 13A socket.

4. COMMISSIONING

1. Turn on the water supply.
2. Turn on the electrical supply.

On initial switch-on only

After a few seconds delay for the electronics to charge, the boiler will begin filling with water and the 'WAIT / READY' light will flash yellow indicating 'WAIT'. When the low water level is reached the element will begin to heat the water. the solenoid will remain on until the normal operating level is reached. Upon reaching the correct temperature the 'WAIT / READY' light will turn solid orange, indicating 'READY AND FULL'.

NOTE : PRE-O1/O6/02 MODELS HAD SLIGHTLY DIFFERENT MODE OF OPERATION

On subsequent operation of the boiler

The unit will fill and heat the water in cycles. The machine will allow only a limited amount of water to enter the unit and then switch off the solenoid and switch on the element.

Figure 4. shows the approximate times for boiling water to be available from the draw off tap, from commissioning. These times will vary depending on the water pressure of the mains water supply.

	Full capacity available after
From empty	45 mins.
After overnight stand (full)	17 mins.

5. USER INSTRUCTIONS

Boiling water is dispensed through the draw off tap, which is operated by pulling the handle forward towards the user. ***Due caution should be exercised as the water is approximately 98° C. at all times.*** The tap handle will automatically return to the off position unless pulled fully forward to the locking position.

Two lights mounted on the front facia provide a continuous display of the operation of the boiler. During the initial commissioning process or subsequent switch on from cold, the top 'WAIT / READY' light will indicate 'WAIT' by flashing yellow or orange (water is below normal operating temperature). When the boiler has reached the normal operating temperature, the 'WAIT / READY' light will indicate 'READY' by turning to a **solid yellow** if the boiler is only part full, or a **solid orange** light when maximum draw off capacity is available.

If **all** the available water is drawn from the boiler, the flow rate will reduce to a trickle as the unit fills and heats the water (this does not indicate a fault with the boiler). The 'WAIT / READY' light will continue to show 'READY' as the temperature of the water is still approximately 98°C.

5.1 Cleaning

When required the unit should be wiped down using a damp cleaning cloth. This appliance is not protected against the ingress of water and therefore should not be washed down in any manner that would allow water to enter the electrical chamber of the unit e.g. the use of a spray water jet.

5.2 Service Indicator Light

Certain types of operational fault will cause the 'SERVICE INDICATOR' light, mounted on the front fascia, to flash. If this occurs refer to section on 'Fault Finding'.

6. MAINTENANCE

Competent persons must carry out all maintenance work.

When the body lid has been removed, it is recommended that a new body lid gasket be fitted on re-assembly to ensure a steam tight seal. Damage to the unit caused by incorrectly sealed gaskets that should be replaced during maintenance is not covered by the manufacturer's warranty.

6.1 Scale

Your Contour boiler incorporates an integral scale inhibitor. In general, independent users throughout the country have benefitted from either a vastly reduced scale build up, and / or much easier maintenance due to the softer nature of the scale which does not adhere rigidly to the internals of the machine. Please note that this is not a scale eliminator and its effect will differ according to the water quality in your area.

To ensure regular, trouble-free operation, periodically check for scale inside the boiling chamber and around the tap nozzle. The production of scale is a natural phenomenon and some de-scaling may be required within the first 12 months. This is not covered under the product's warranty as it is not a fault.

The solenoid valve is fitted with a removable filter at the inlet point. This filter should be cleaned as required.

Check the extent of scale formation on the element,

6.1.1 Checking the Extent of Scale Formation

1. Remove the body lid by releasing the four fixing screws. **To remove the lid it must be pushed forwards to the front of the boiler before lifting to allow the condenser mechanism to clear the body top flange. See fig.5**

Fig 5.

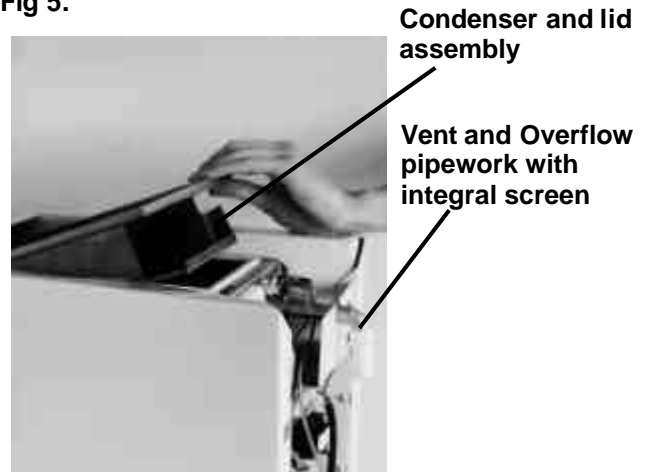

It is very important that the lid assembly be fitted the correct way round for the condenser to work effectively. See label on top of lid

IMPORTANT It is recommended that a new body lid gasket be fitted on re-assembly to ensure a steam tight seal. Damage to the unit caused by incorrectly sealed gaskets that should be replaced during maintenance is not covered by the manufacturer's warranty.

6.1.2 De-scaling

Scale deposits should be removed from all internal surfaces, particularly the heating element, thermistor pocket and level sensor probes by gently tapping or scrapping. If the deposits are soft, use a nylon pad and flush out. Abrasive cleaning materials containing scouring powders and detergents must not be used, such materials can cause taste problems. Chemical descalants must only be used in accordance with the manufacturer's instructions.

IMPORTANT All chemical agents must be completely flushed out to avoid taste problems health risks and possible signaling failures.

IMPORTANT Before re-commissioning the boiler it is important that all scale and moisture is removed from the level sensor insulating gaskets to avoid a false signal being transmitted through the scale to the boiler body. Failure to remove this scale could cause the sensors to indicate to the PCB that water is covering the element, whether or not water is present. In this situation the PCB could energize the element causing failure. If in doubt protect the element by hand filling with water to the level of the draw-off tap before switching the boiler electrical supply on.

6.2 Replacing the Element and Thermistor

The element and thermistor can be replaced by removing the back-nuts and washers and withdrawing from inside the body. **IMPORTANT: a new body lid gasket may be required.**

6.3 Replacing the Printed Circuit Board (PCB)

IMPORTANT: both the main printed circuit board and the Triac printed circuit board must be replaced as a matched pair.

1. Disconnect the wiring connections to the Main PCB
2. Remove the PCB by pulling it forward off the supports.
3. Disconnect the wiring connections to the Triac PCB
4. Remove the Triac PCB by releasing the fixing screw and pulling it forward off the supports.
5. Apply a thin covering of heat transfer compound (supplied) to the mounting platform of the new Triac PCB and fit the new triac P.C.B. onto the two P.C.B. supports, ensure it is positively located **and secure it with the single fixing screw.**
6. Reconnect the Triac wiring connections, see the circuit diagram on page 6.
7. Position the main P.C.B. on the four supports, ensuring that the P.C.B. is positively located. Reconnect the P.C.B. wiring connections, see the circuit diagram on page 6.

6.4 Replacing the Solenoid

IMPORTANT: In areas where scale can be a problem, check that the suspected fault is not due to a blocked filter (this is removable at the inlet to the solenoid) before replacing the unit. Scale build-up in the filter can cause intermittent problems.

1. Remove the silicone hose that joins the solenoid to the water inlet. **Warning the pipe will retain a volume of water that will be released when the connection is broken.**
2. Pull the solenoid from the mounting bracket.
IMPORTANT: The correct operation of the boiler relies on a regulated flow of water from the solenoid valve and therefore a genuine replacement part supplied by Calomax must be fitted.
3. Fit the replacement valve onto the existing mounting bracket (if a mounting bracket was supplied with the new valve, remove this first).

6.5 Checking the Overflow Screen

The Overflow screen can be viewed by disconnecting the overflow pipe-work from the boiler. The screen is housed in the pipe-work indicated in fig.5. Check the screen for blockage. The overflow screen can be cleaned or replaced with a new part (supplied by Calomax) as required.

6.6 Adjusting the Water Temperature Set Point

The temperature potentiometer (Pot) is pre-set at Calomax and will only require adjustment in exceptional circumstances.

The temperature adjustment Pot 1 (located at the bottom left hand corner of the main printed circuit board) controls the operating temperature of the boiler. ½ turn clockwise on this device will raise the temperature of the water by approximately 1 ½ degrees centigrade. **Water boils at different temperatures depending on barometric pressure. The temperature should not be tuned higher than the pre-set 98 degrees, or overboiling may occur during low barometric pressure conditions, causing the unit to trip the overheat cut-out device.**

7. FAULT FINDING

To protect the unit in the event of continuous over boiling, the unit is fitted with a thermal cut out device. This device will cut power to the entire machine and can be re-set manually. Before re-setting the device, the cause of the trip.(de-scale required etc.) should be investigated.

The Service Indicator Light on the front of the machine and Light Emitting Diodes (LED's) fitted to the Main PCB, can be used to diagnose operating problems with the machine.

Certain types of operational fault will cause the green 'SERVICE INDICATOR' light, mounted on the front facia, to flash certain sequences.

.A **two**-light pulse generally indicates that the low level probe requires a de-scale .

A **three**-light pulse indicates a loss of signal from the normal water level probe causing the unit to overfill, The probe requires a de-scale.

A **four**-light pulse indicates the machine has over-filled due to debris trapped in the solenoid valve. This is usually solved by drawing **all** water from the tap, causing the valve to operate and flush out the obstruction. The machine will reset itself once the problem has cleared. If this does not rectify the problem, turn off the water supply and remove the flexible hose to check for debris in the valve's filter.

A **five**-light pulse indicates the boiler has over filled due to scale on both the low and normal level sensors.

A **six**-light pulse indicates the machine has over-filled due to debris trapped in the solenoid valve.(**see four pulse**) but also the low level probe requires a descale.

The unit can be used normally while the service indicator is flashing

LED's fitted to the Main PCB indicate the operation of the solenoid and element. The red LED indicates that the element should be energized and the yellow LED indicates that the solenoid should be energized. The switching of the element and solenoid is all solid state, driven by the PCB's .In all cases the power to the element and solenoid is switched through the neutral connection.

For further information contact Calomax Ltd direct.

WIRING DIAGRAM FOR CONTOUR WATER BOILERS issue1 1/1/01

